

INSTRUCTIONS

FOR INSTALLATION, OPERATION AND MAINTENANCE OF

Wafer Type Swing Check Valves acc. to
BS 1868 / API 594 / API6D [CSWAPI]

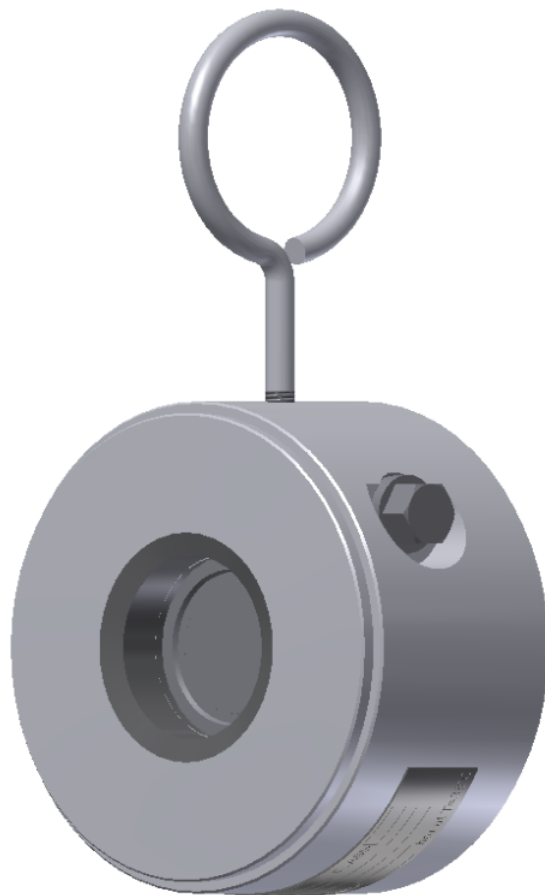

Table of Contents

| | |
|---|----------|
| 1. General safety information's | 3 |
| 2. Product description | 3 |
| 3. Transport and storage | 5 |
| 4. Installation and start-up | 5 |
| 5. Usage and maintenance | 7 |
| 6. Service and repair | 8 |
| 7. Possible malfunctions and solutions | 8 |
| 8. Guarantee | 9 |



1. General safety information's

Instructions for installation, start-up and maintenance during the period of exploitation of valves manufactured in the “Termovent SC” should be used as a manual intended for all personnel directly or indirectly involved in dealing with the aforementioned goods.

These instructions are only related to Wafer type swing check valves.

Operators in charge of installation, operation and maintenance of valves during the period of use, should be fully trained for the correct / optimal performance of these tasks.

Because wafer type swing check valves in working conditions have hot parts (body and cover) and may cause burns, the operator has an obligation to undertake all necessary precautions to avoid such by using protective facilities.

Before the service or reinstallation of the valves, the plant or installation should be taken out of operation (pressure 0 bar, temperature of valves should be the same temperature as the environment).

These products are recyclable. No ecological hazard is anticipated with the disposal of these products providing due care is taken.

2. Product description

The main purpose of the Wafer type swing check valves is to stop fluid flow through pipeline in one direction.

If anything is unclear at the time of installation, start-up or during use, and not covered in these instructions, the departments of the “Termovent SC” should be contacted directly in order to obtain the required support.

All Wafer type swing check valves manufactured in “Termovent SC” are marked with following marks:

- Identification of manufacturer (“Termovent SC” logo);
- Nominal diameter of valve NPS(inch) or DN (mm);
- Nominal pressure Class rating (#);
- Material designation of body;
- Body melt identification/heat number;
- Trim identification- material grade for disc and seat;



- Unique serial number;
- Arrow mark for allowable direction of flow;
- Date of manufacture (month and year) ;
- Maximum allowable pressure at maximal temperature according to ANSI B16.34
- The product standard designation: i.e. API 594
- API marking (if it is manufactured in accordance with API specification)
- Other marks in accordance with customer request or product standard.

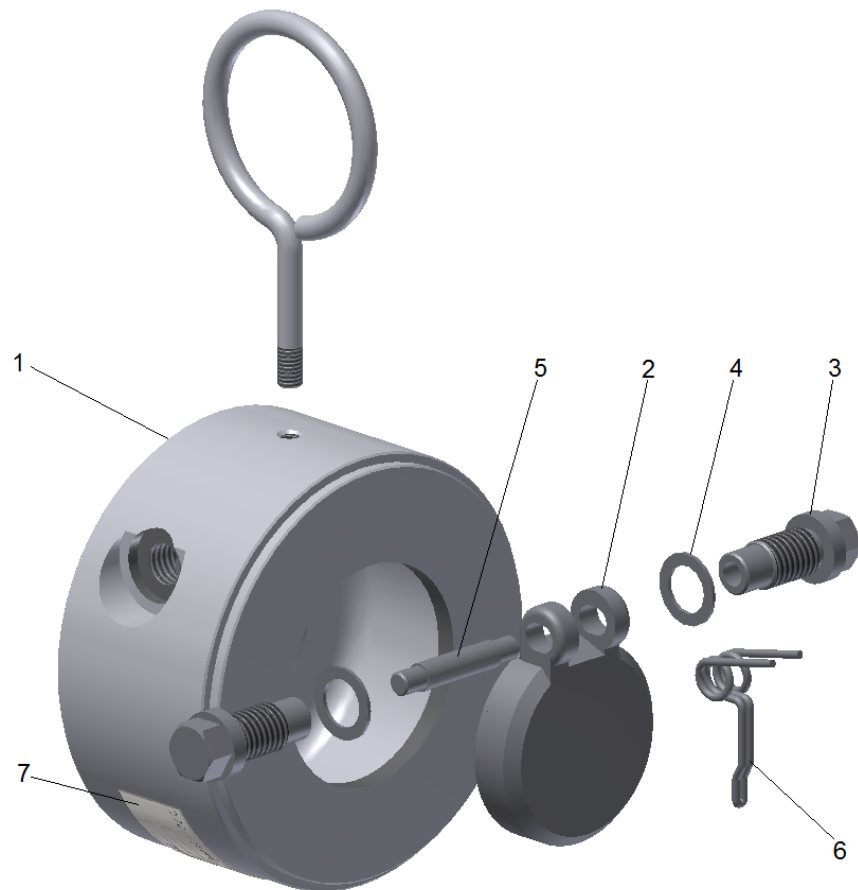

Fig. 1 Parts

Table 1

| Pos. | Part Name | Quantity | Spare Parts |
|------|------------|----------|-------------|
| 1 | Body | 1 | |
| 2 | Disc | 1 | |
| 3 | Pin Holder | 2 | |
| 4 | Washer | 2 | |
| 5 | Pin | 1 | |
| 6 | Spring | 1 | |
| 7 | Nameplate | 1 | |

3. Transport and storage

Transport and storage of wafer type swing check valves should be performed at a temperature between -20°C to $+60^{\circ}\text{C}$ and should be protected against outer and atmospheric influences, as well as protecting painted surfaces against damage. The purpose of painted surfaces is to protect valves against corrosion during transport and storage.

The basic version of wafer type swing check valves are protected with particular/special paints applied to the outer parts and protective preservatives inside. As such, any corrosion is prevented for a period of 6 months. Protection for special conditions is applied only with prior agreement.

It is recommended to store the wafer type swing check valves in closed, dry and ventilated storage facilities and to protect valves against any atmospheric influence. In order to avoid the appearance of corrosion before the expiry of protection it is necessary to store the valves on a pallet/crate or other appropriate place.

WARNING !!!

- You must not remove the protection covers from the valve connection ends

4. Installation and start-up

After the removal of the protection covers it is necessary to thoroughly clean inside the swing check valve with compressed air.



At the moment of installation the influence of the load of the pipeline on the valve should be reduced. The same also applies for temperature oscillation, hydraulic impact and similar. The valve should not be used as a support for a pipeline.

It is important to take care about the flow direction at the time of installation. The flow direction is indicated with the arrow mark casted or imprinted on the body of the swing check valve.

Mounting position must be in accordance with the instructions in this guide (Fig. 2)

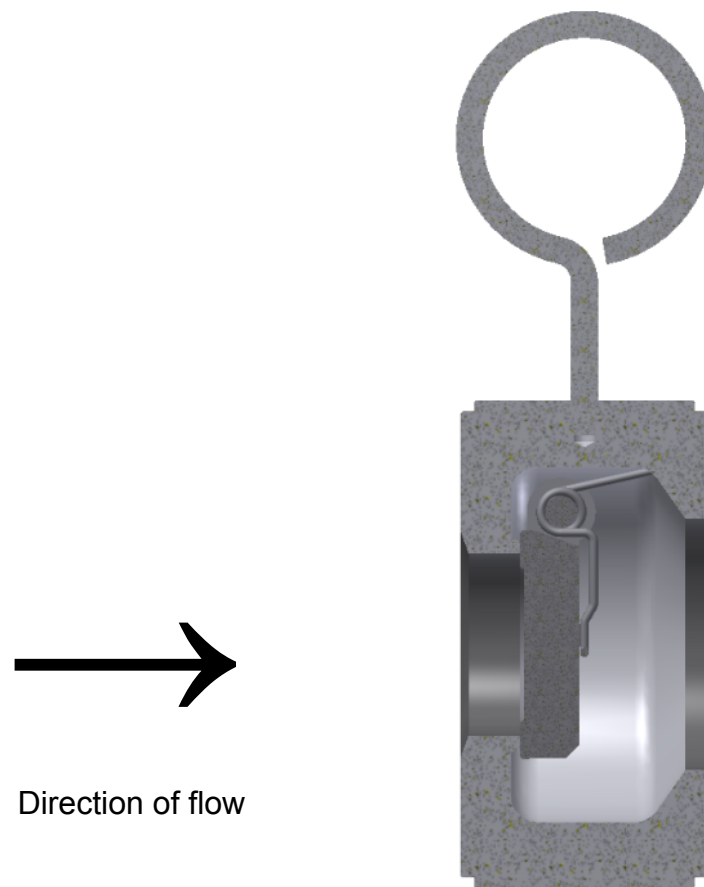

Fig. 2 Allowed mounting position

WARNING !!!

- Before installation the impurities should be removed from the pipeline or from the appliance;
- Remove protecting covers from the valve ends, degrease and clean the inside of the valve, and in case of a flanged connection, carefully clean the sealing surfaces;
- Confirm that the marks on the swing check valve correspond to the projected parameters of the plant (e.g. size, pressure, material etc.) and installation is according to allowable flow direction;
- Confirm that the velocity of the fluid at the place of the installation is in range of the recommended velocity;
- At the moment of testing of a pipeline or an installed appliance valve; take care about the predicted maximal differential pressure.
- **The valve should not be used as a support for a pipeline.**

5. Usage and maintenance

It is convention during usage of the valves that all minor defects, if operating conditions allow, should be repaired on the spot. If not, the valve should be dismantled from the site in order to perform a full repair. If the valve is severely damaged it should be replaced with a new one. Such repairs protect valves against further deterioration, being permanently out of work and being the cause of severe accidents in the plant.

WARNING !!!

- If, when a valve is overhauled, a decrease of wall thickness of more than 30% is detected at any of the ports (due to erosion) the valve should stop being used;
- Valve maintenance and manipulation during use should be done only by experts and persons well trained for such purpose;
- At the moment of installation of the plant sudden and extreme change of pressure and temperature should be avoided;
- A Strainer being installed before the swing check valve will increase its reliability and proper working



6. Service and repair

Only authorized persons should perform service and repair with appropriate tools and, if it is possible, using original spare parts. Personal protection should be applied in accordance with valid regulations and legalizations.

Attention should always be paid to the reliability of the valves and parameters of the working implementation / plant, and only materials which can successfully replace those originally installed should be used.

For highly reliable valves (valves which work with high temperatures, high pressures or with dangerous fluids) any service, repair or replacement should be done professionally and responsibly in accordance with valid regulations for safe working conditions at the plant.

Before the service or reinstallation of the valves, the plant or installation should be taken out of operation (pressure 0 bar, temperature of valves should be the same temperature as the environment).

Every Swing Check Valves serviced or repaired should be subject to all necessary tests usually performed for a newly produced Swing Check Valve.

7. Possible malfunctions and solutions

During the period of usage of the installed valve malfunctions may occur. Only experts in the premises of the user should undertake repairs. The most common cause of malfunctions and how to overcome such situations is listed in Table 2.



Table 2

| Failure | Possible cause | Troubleshooting |
|-------------------------------|---|--|
| Absence of flow | Protection covers are not removed | Remove protection covers from connection ends |
| | Improperly installed product in relation to the allowed flow | Install valve in allowed flow direction |
| | Improperly installed product in relation to the permitted mounting position | Install valve in in allowed mounting position |
| Leakage on connection gaskets | Connecting Nuts are not tightened | Tighten connecting nuts |
| | Gaskets are damaged | Replace gaskets with new ones |
| Leaking on the seat | Mechanical damages of seat or disc (Pos.2) | Contact the manufacturer |
| | Working medium contains solid particles | Clean Valve thoroughly. We recommend installation of Strainer before Check Valve |

8. Guarantee

The Guarantee issued by “Termovent SC” confirms the safe working of its products under conditions when these products are properly installed in accordance with the instructions in the documentation given to the customer, and usage is in accordance with approved technical conditions and working parameters.

The Guarantee is void if inappropriate parts from other manufacturers are implemented, if the user changes construction, or if there is any decline in function or malfunction due to natural wear and tear.

Guarantee conditions:

The Guarantee is valid for defective parts or defective products, when any such defect is confirmed by an expert engaged by the customer and approved by experts from our company. In such a situation “Termovent SC” will replace the defective part(s) or defective product(s).

Replacement of defective part(s) or defective product(s) with new one(s) should be done only by an expert engaged by the customer upon approval or by instruction of our experts and in accordance with the instructions for installation.



The Guarantee period is not valid if installation and manipulation of the valves isn't in accordance with these instructions. The Guarantee period for all replaced parts or product(s) starts from the moment the replacement(s) is/are done.

Guarantee is valid only for following storage and maintenance conditions:

Crate and pallets with valves should be stored indoors in a building with access limited to authorized personnel only. In the case of an inappropriate storage place crates (or pallets) should be stored under an awning and should be protected against rain and moisture with an appropriate waterproof cover, again with access limited to authorized personnel only.

Valves should only be taken out of a crate or removed from the covering of a pallet just before installation and only quantity to be installed should be taken out / removed. After the valves for installation are taken out of a crate (or pallet) the crate/pallet should be closed/covered again.

Do not remove the protector covers from valves until installation.

Valves prepared for installation should be manipulated and transported in a careful manner to prevent possible mechanical damage.

WARNING !!!

- After detection of mistakes "Termovent SC" should be informed immediately.
- Claims must be made in writing.

