

# INSTRUCTIONS

## FOR INSTALLATION, OPERATION AND MAINTENANCE OF

---

Xmas Tree Gate Valve  
according to API 6A [GXT]

---

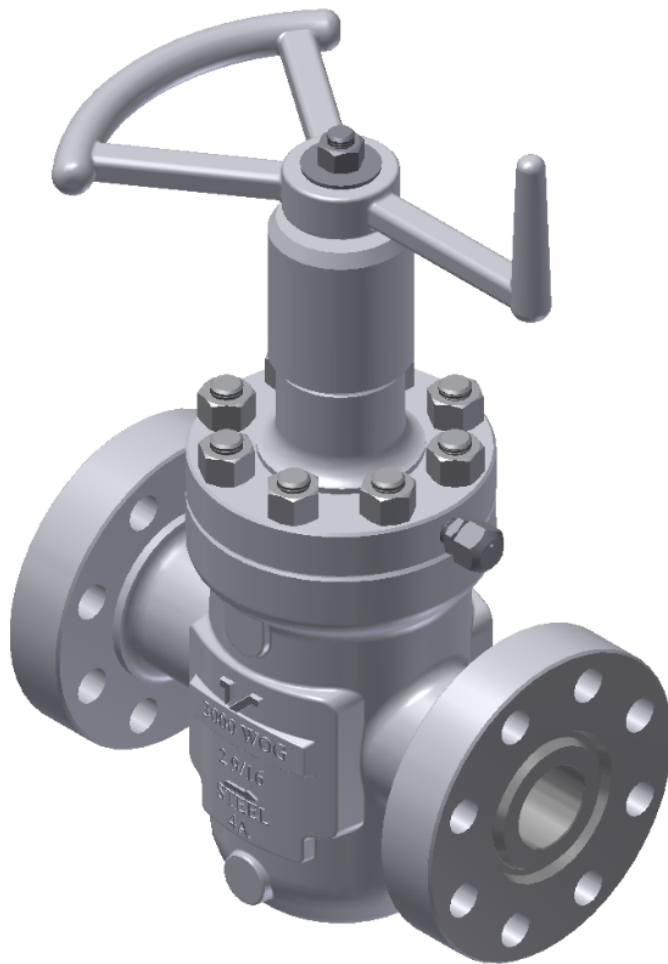

## Table of Contents

<b>1. General safety information's</b>	<b>3</b>
<b>2. Product description</b>	<b>3</b>
<b>3. Transport and storage</b>	<b>6</b>
<b>4. Installation and start-up</b>	<b>7</b>
<b>5. Usage and maintenance</b>	<b>8</b>
<b>6. Service and repair</b>	<b>10</b>
<b>7. Possible malfunctions and solutions</b>	<b>10</b>
<b>8. Guarantee</b>	<b>11</b>



## 1. General safety information's

Instructions for installation, start-up and maintenance during the period of exploitation of valves manufactured in the “Termovent SC” should be used as a manual intended for all personnel directly or indirectly involved in dealing with the aforementioned goods.

These instructions are only related to Xmas Tree Gate Valves [GXT].

Operators in charge of installation, operation and maintenance of valves during the period of use, should be fully trained for the correct / optimal performance of these tasks. If gate valves are equipped with mechanical actuators, the operator should be trained for the adequate operation of such valves.

Before the service or reinstallation of the valves, the plant or installation should be taken out of operation (pressure 0 bar, temperature of valves should be the same temperature as the environment).

Because valves in working conditions have hot parts (handwheel, body and bonnet) and may cause burns, the operator has an obligation to undertake all necessary precautions to avoid such by using protective facilities.

These products are recyclable. No ecological hazard is anticipated with the disposal of these products providing due care is taken.

## 2. Product description

The main purpose of the gate valves is to isolate fluid flow through pipeline.

If anything is unclear at the time of installation, start-up or during use, and not covered in these instructions, the departments of the “Termovent SC” should be contacted directly in order to obtain the required support.

All gate valves manufactured in “Termovent SC” are marked with following marks:

- Identification of manufacturer (“Termovent SC” logo);
- Identification of valve type: GXT
- Nominal size of valve NPS (inch) or DN (mm);
- Rated working pressure (psi);
- Performance Requirements Level;



- Product Specification Level;
- Temperature class or upper and lower operating temperature range;
- Material designation of body and bonnet;
- Body and bonnet melt identification/heat number;
- Trim identification- material grade for stem, wedge and seats;
- Unique serial number;
- Date of manufacture (month and year) ;
- The product standard designation: API 6A
- Valve ends flanges grooved with ring joints corresponding ring number and type;
- API marking (if it is manufactured in accordance with API Specification)
- Other marks in accordance with customer request or product standard.



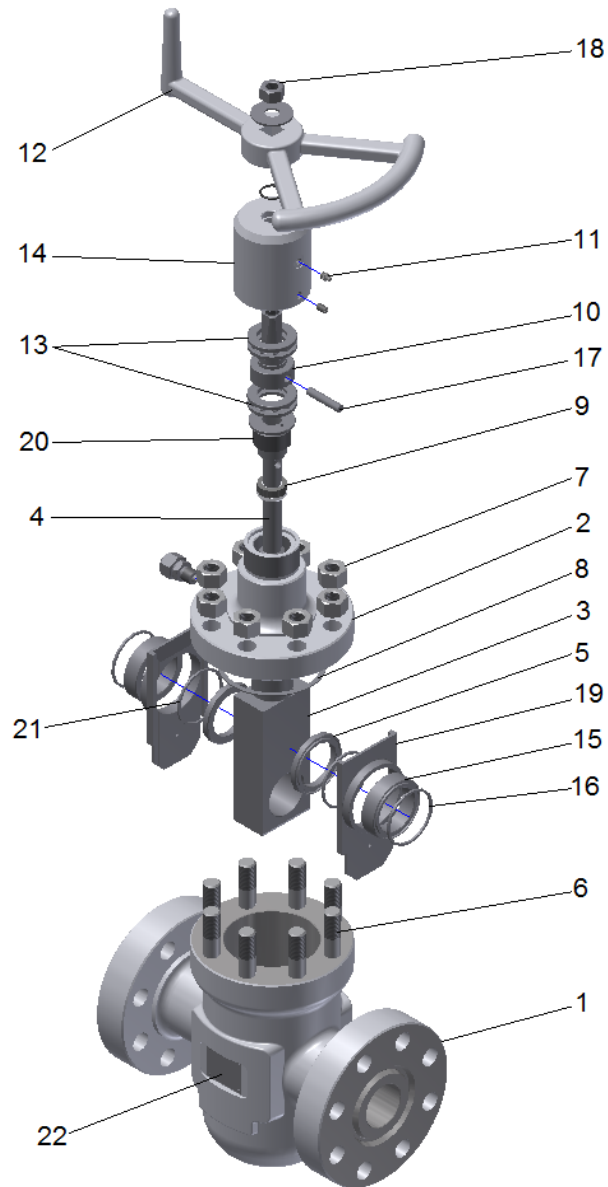

**Fig. 1 Parts names**

**Table 1**

Pos.	Part Name	Quantity	Spare Parts
1	Body	1	
2	Bonnet	1	
3	Wedge	1	
4	Stem	1	
5	Seats	2	YES



6	Stud bolts	*	
7	Nuts	*	
8	Bonnet gasket	1	YES
9	Stem Packing	1	YES
10	Stem Extension	1	
11	Grase injector	1	
12	Handwheel	1	
13	Bearings	2	
14	Bonnet Cover	1	
15	Secondary Seats	2	YES
16	PTFE Secondary Seat Gasket	2	YES
17	Pin	1	
18	Handwheel nut	1	
19	Wedge giude	2	
20	Stem guide	1	
21	PTFE Seat Gasket	2	YES
22	Nameplate	1	

\* Quantity depend from DN (NPS) and PN (Class)

### 3. Transport and storage

Transport and storage of valves should be performed at a temperature between -20°C to +60°C and should be protected against outer and atmospheric influences, as well as protecting painted surfaces against damage. The purpose of painted surfaces is to protect valves against corrosion during transport and storage.

The basic version of valves are protected with particular/special paints applied to the outer parts and protective preservatives inside. As such, any corrosion is prevented for a period of 6 months. Protection for special conditions is applied only with prior agreement.

It is recommended to store the valves in closed, dry and ventilated storage facilities and to protect valves against any atmospheric influence. In order to avoid the appearance of corrosion before the expiry of protection it is necessary to store the valves on a pallet/crate or other appropriate place.



**WARNING !!!**

- You must not lift the valves using the connection flange holes or the handwheel – you should use lifting straps;
- You must not remove the protection covers from the valve connection ends;
- Store the valves in the ‘closed’ position.

## 4. Installation and start-up

Gate valves are delivered with their wedge in the closed position and they are ready for use. After the removal of the protection covers it is necessary to thoroughly clean inside the valve with compressed air without first opening the valve.

Closure of a valve is performed by turning the handwheel in a clockwise direction. On the handwheel is an arrow and the letter “C” indicating the closing direction, and another arrow and the letter “O” indicating the opening direction.

When installing valves with flanged ends it is necessary to take into consideration the selection of adequate bolt material and the appropriate type of gasket depending on the type of working fluid, pressure, temperature, and the type of flange facing. It is necessary to install gaskets strictly in accordance with instructions given from the manufacturer of the gaskets.

Gate valves with threaded ends should be mounted onto the pipeline in the closed position by an expert and with appropriate thread sealing compound.

At the moment of installation the influence of the load of the pipeline on the valve should be reduced. The same also applies for temperature oscillation, hydraulic impact and similar. The valve should not be used as a support for a pipeline.



**WARNING !!!**

- Each product after assembling is hydraulically tested the result of which is “wetting” of the sealing package. As a result, may be difficult manipulation with handwheel before installation. This do not effect on the functionality of product and this phenomenon will be eliminated after installation gate valve on the pipeline;
- You must not lift the gate valves using the connection flange holes or the hand wheel at the moment of the installation the gate valve on the pipeline – you should use lifting straps to secure the valves to the lifting equipment;
- Before installation the impurities should be removed from the pipeline or from the appliance;
- Remove protecting covers from the gate valve ends, degrease and clean the inside of the gate valve, and in case of a flanged connection, carefully clean the sealing surfaces;
- Confirm that the marks on the gate valve correspond to the projected parameters of the plant (e.g. size, pressure, material etc.);
- Confirm that the velocity of the fluid at the place of the installation is in range of the recommended velocity;
- During the installation check if there is enough space for normal and safe manipulation;
- At the moment of testing of a pipeline or an installed appliance valve; take care about the predicted maximal differential pressure
- **The valve should not be used as a support for a pipeline.**

## 5. Usage and maintenance

It is convention during usage of the gate valves that all minor defects, if operating conditions allow, should be repaired on the spot. If not, the gate valve should be dismantled from the site in order to perform a full repair. If the gate valve is severely damaged it should be replaced with a new one. Such repairs protect gate valves against further deterioration, being permanently out of work and being the cause of severe accidents in the plant.

In case of leakage through gaskets between gate valve connection flanges or between the bonnet and body, it is necessary to make replacements of the gaskets as soon as possible to prevent damage of the sealing surfaces due to erosion.

The gate valves equipped with grease nipple should be lubricated every month, or twice a year, if they are rarely used. It is recommended to





replace the grease in bushes during every general overhaul or during the pipeline revision. The type of grease depends on the temperature in the plant. Remote controls, bushings and gearboxes should be lubricated depending on how frequently they are used, every six or twelve months.

Gate valves delivered with actuator is adjusted for proper work. Gate valves delivered with connection for later build on it the electric actuator must be adjusted. Closing of gate valves should be adjusted by torque switch and the opening by limit switch. The setting of torque and limit switches must be in accordance with the instructions of the manufacturer of the actuator.

ATTENTION - ВНИМАНИЕ - PAŽNJA !		
<b>CLOSED</b> <b>ЗАКРЫТО</b> <b>ZATVOREN</b>		stop by torque switch отключение по моментным выключателям zaustavljanje prekidačem momenta
<b>OPEN</b> <b>ОТКРЫТО</b> <b>OTVOREN</b>		stop by limit switch отключение по концевым выключателям zaustavljanje prekidačem položaja

### WARNING !!!

- During usage gate valves must be completely in an open or closed position;
- If, when a gate valve is overhauled, a decrease of wall thickness of more than 30% is detected at any of the ports (due to erosion) the valve should stop being used;
- Any time when a gate valve is dismantled or reinstalled the gaskets should be replaced with new ones with the appropriate quality;
- Valve opening and closing by handwheel, should be done without use of auxiliary means such as a rod or similar;
- Valve maintenance and manipulation during use should be done only by experts and persons well trained for such purpose;
- At the moment of installation of the plant sudden and extreme change of pressure and temperature should be avoided.
- **Gate valve can not be used for flow control.**



## 6. Service and repair

Only authorized persons should perform service and repair with appropriate tools and, if it is possible, using original spare parts. Personal protection should be applied in accordance with valid regulations and legalizations.

Attention should always be paid to the reliability of the valves and parameters of the working implementation / plant, and only materials which can successfully replace those originally installed should be used.

For highly reliable valves (valves which work with high temperatures, high pressures or with dangerous fluids) any service, repair or replacement should be done professionally and responsibly in accordance with valid regulations for safe working conditions at the plant.

Before the service or reinstallation of the valves, the plant or installation should be taken out of operation (pressure 0 bar, temperature of valves should be the same temperature as the environment).

Every gate valve serviced or repaired should be subject to all necessary tests usually performed for a newly produced gate valve.

Bolts for connection between body and bonnet should be tightened evenly and crosswise applying appropriate torque when the gate valve is in the open position.

Possible torques for tightening are listed in Table 2 and the selection of torque depends on the material grade of bolts and nuts used, as well as the quality of the gasket of the bonnet.

**Table 2**

Rated Pressure	2000 psi				5000 psi	
Valve Size	2 1/16	2 9/16	3 1/8	4 1/16	2 1/16	2 9/16
Thread	M14	M24	M24	M27	M24	M27
Torque /Nm/	100	500	500	730	500	730

## 7. Possible malfunctions and solutions

During the period of usage of the installed gate valve malfunctions may occur. Only experts in the premises of the user should undertake repairs. The most common cause of malfunctions and how to overcome such situations is listed in Table 3.



**Table 3**

<b>Failure</b>	<b>Possible cause</b>	<b>Troubleshooting</b>
Absence of flow	Gate valve is in closed position	Open the gate valve
	Protection covers are not removed	Remove protection covers from connection ends
Reduced or aggravated flow	Gate valve is not completely open	Open the valve completely with handwheel (Pos.12)
	Dirty gate valve or pipeline	Check and clean gate valve or pipeline
Difficult manipulation	Ungreased bearings (Pos. 13)- stem extension (Pos. 10)	Greased bearings – stem extension by grease nipple (Pos.11)
Leakage on bonnet gasket	Nuts (Pos.7) are not tightened	Tighten Nuts (Pos.7)
	Bonnet gasket (Pos.8) is damaged	Disassemble bonnet (Pos.2) and replace bonnet gasket (Pos.8) with new one
Leakage on stem packing	Stem packing (Pos.9) lost own functionality	Completely open the valve and and replace stem packing (Pos.9) with new one
Leaking on seat	Gate valve isn't completely closed	Turn handwheel (Pos. 12) in direction indicated for closing without auxiliary means
	Mechanical damages of seat or wedge	Contact the manufacturer

## 8. Guarantee

The Guarantee issued by “Termovent SC” confirms the safe working of its products under conditions when these products are properly installed in accordance with the instructions in the documentation given to the customer, and usage is in accordance with approved technical conditions and working parameters.



The Guarantee is void if inappropriate parts from other manufacturers are implemented, if the user changes construction, or if there is any decline in function or malfunction due to natural wear and tear.

### **Guarantee conditions:**

The Guarantee is valid for defective parts or defective products, when any such defect is confirmed by an expert engaged by the customer and approved by experts from our company. In such a situation “Termovent SC” will replace the defective part(s) or defective product(s).

Replacement of defective part(s) or defective product(s) with new one(s) should be done only by an expert engaged by the customer upon approval or by instruction of our experts and in accordance with the instructions for installation.

The Guarantee period is not valid if installation and manipulation of the valves isn't in accordance with these instructions. The Guarantee period for all replaced parts or product(s) starts from the moment the replacement(s) is/are done.

### **Guarantee is valid only for following storage and maintenance conditions:**

Crate and pallets with gate valves should be stored indoors in a building with access limited to authorized personnel only. In the case of an inappropriate storage place crates (or pallets) should be stored under an awning and should be protected against rain and moisture with an appropriate waterproof cover, again with access limited to authorized personnel only.

Gate valves should only be taken out of a crate or removed from the covering of a pallet just before installation and only quantity to be installed should be taken out / removed. After the gate valves for installation are taken out of a crate (or pallet) the crate/pallet should be closed/covered again.

Do not remove the protector covers from gate valves until installation.

Gate valves prepared for installation should be manipulated and transported in a careful manner to prevent possible mechanical damage.

### **WARNING !!!**

- After detection of mistakes “Termovent SC” should be informed immediately.
- Claims must be made in writing.

