



IOM - Instructions for installation,
operation and maintenance of:

Small Forged Gate Valves

according to EN 1984

[GENF]

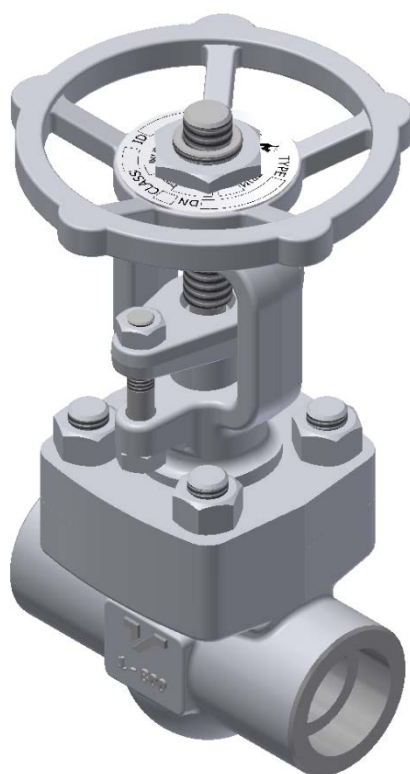

“TERMOVENT” SC
Temerin

Republic of Serbia

Table of Contents

1. General safety information's	3
2. Product description	3
3. Transport and storage.....	Error! Bookmark not defined.
4. Installation and start-up.....	5
5. Usage and maintenance	6
6. Service and repair	8
7. Possible malfunctions and solutions	9
8. Guarantee	9

1. General safety information's

- Instructions for installation, start-up and maintenance during the period of exploitation of valves manufactured in the "TERMOVENT" SC should be used as a manual intended for all personnel directly or indirectly involved in dealing with the aforementioned goods.
- These instructions are only related to Small Forged Gate Valves.
- Operators in charge of installation, operation and maintenance of gate valves during the period of use, should be fully trained for the correct / optimal performance of these tasks. If gate valves are equipped with mechanical actuators, the operator should be trained for the adequate operation of such valves.
- Information about temperatures and allowable working pressures shown in our technical data sheets are according to EN 12516. Under no circumstances should the valves be operated at conditions outside these tables.
- Before the service or reinstallation of the gate valves, the plant or installation should be taken out of operation (pressure 0 bar, temperature of valves should be the same temperature as the environment).
- Because valves in working conditions have hot parts (handwheel, body and bonnet) and may cause burns, the operator has an obligation to undertake all necessary precautions to avoid such by using protective facilities.
- These products are recyclable. No ecological hazard is anticipated with the disposal of these products providing due care is taken.

2. Product description

- The main purpose of the gate valves is to isolate fluid flow through pipeline.
- If anything is unclear at the time of installation, start-up or during use, and not covered in these instructions, the departments of the "TERMOVENT" SC should be contacted directly in order to obtain the required support.

All gate valves manufactured in "TERMOVENT" SC are marked with following marks:

- Identification of manufacturer ("TERMOVENT" SC logo);
- Nominal diameter of gate valve DN (mm);
- Nominal pressure PN (#);
- Material designation of body and bonnet;
- Body and bonnet melt identification/heat number;
- Trim identification- material grade for stem, wedge and seats;
- Unique serial number;
- Date of manufacture (month and year) ;
- Maximum allowable pressure at maximal temperature according to EN 12516;
- The product standard designation: EN 1984;
- Valve ends flanges and body/bonnet flanges grooved with ring joints corresponding ring number;
- CE marking (if it is manufactured in accordance with 2014/68/EU (PED 97/23/EC));
- Other marks in accordance with customer request or product standard.

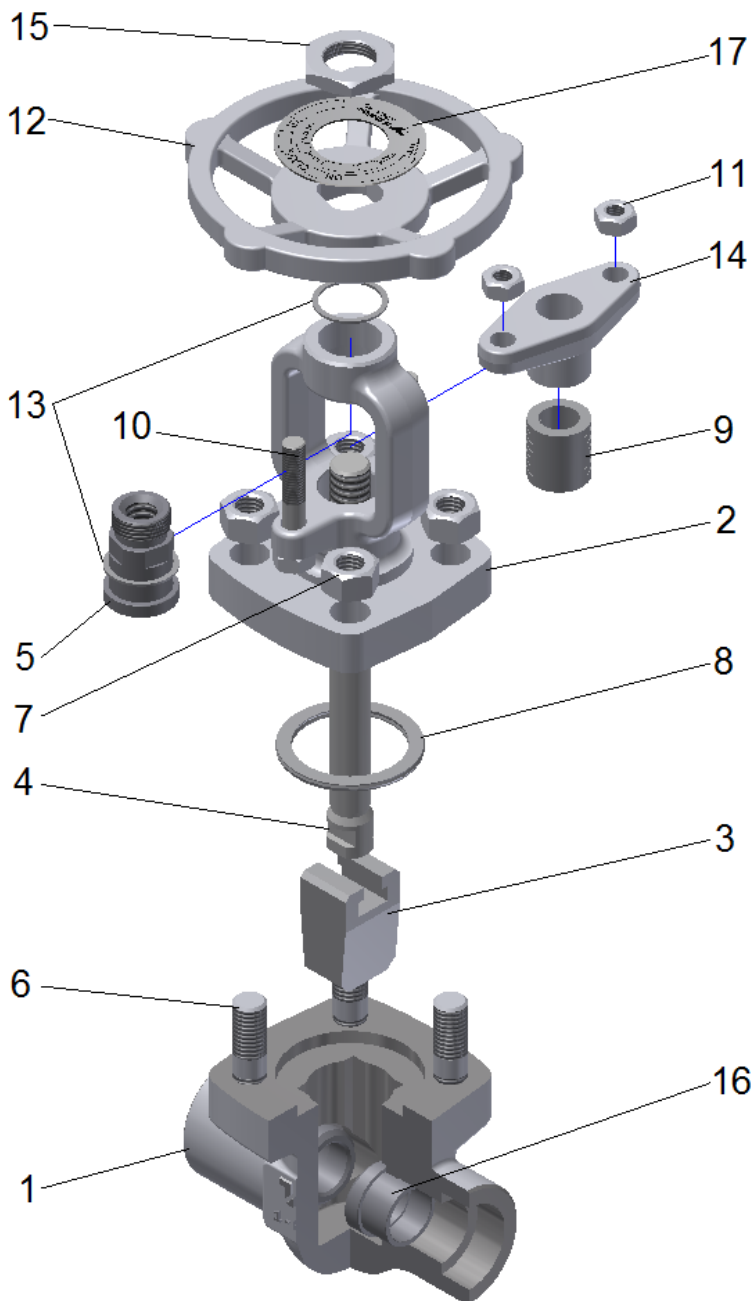

Table 1.

Pos.	Part Name	Quantity	Spare Parts
1	Body	1	
2	Bonnet	1	
3	Wedge	1	
4	Stem	1	
5	Stem Nut	1	
6	Stud bolts	4	
7	Nuts	4	
8	Bonnet gasket	1	YES
9	Stem Packing	1 set	YES
10	Gland Bolts	2	
11	Gland Nuts	4	
12	Handwheel	1	
13	Bearing bushes	2	
14	Gland	1	
15	Handwheel nut	1	
16	Body seat	2	
17	Nameplate	1	

Fig. 1 Parts name

3. Storage and handling

General information

Gate valves are delivered in their wedge in closed position with protective covers on their ends. During storage period protective covers shall not be removed.

3.1 Recommended storage facilities

- The valves have to be stored in closed, clean, dry and ventilated storage facilities.
- Storage conditions shall be: ambient temperature in the range +10°C to +35°C and the humidity up to 85%
- Store the valves in their original shipped packing.
- Gate valves should be taken out of crates or removed from the covering of a pallet just before installation.

3.2 Storage inspection

- Periodical inspection should be performed on all stored valves. At the minimum, all valves should be inspected every 3-4 months for dirt, moisture or any other type of contamination. If any is found the valves is to be thoroughly cleaned and dried.
- Slight external rusting may occur on valves. This will have no effect on their performance.
- If valves are stored for more than 6 months we recommend following:
 - Valves shall be cycled open to close 2-3 times every 6 months to keep packing from adhering to the stem and help lubricate the stem and stem nut.
 - Preservation of inner surfaces, inner parts, stem, flange facing, butt welding ends and threads shall be repeated every 6 months with appropriate corrosion preventive coating
 - Re-tighten diametrically opposite all the bolts as per factory specifications to overcome possible bolt relaxation during long-term storage (Fig.4)

3.3. Handling requirements

- For valve handling and/or lifting the lifting equipment must be sized and selected while taking into account the valve weight indicated at packing list. Lifting and handling must be made only by qualified personnel. Do not use the lifting points located on the actuator. Caution must be taken during the handling to avoid that this equipment passes over the workers. For valve handling or lifting the lifting equipment must be sized and selected while taking or over any other place where a possible fall could cause damage.

WARNING!!!

- You must not lift the valves using the connection flange holes or the handwheel – you should use lifting straps;
- You must not remove the protection covers from the valve connection ends;
- Store the valves in the 'closed' position.

4. Installation and start-up

- Gate valves are delivered with their wedge in the closed position and they are ready for use. After the removal of the protection covers it is necessary to thoroughly clean inside the gate valve with compressed air without first opening the valve.
- Do not disassemble or modify a valve in any way prior to installation. This will void the factory warranty.
- Closure of a valve is performed by turning the handwheel in a clockwise direction. On the handwheel is an arrow and the letter "C" indicating the closing direction, and another arrow and the letter "O" indicating the opening direction.
- When installing gate valves with flanged ends it is necessary to take into consideration the selection of adequate bolt material and the appropriate type of gasket depending on the type of working fluid, pressure, temperature, and the type of flange facing. It is necessary to install gaskets strictly in accordance with instructions given from the manufacturer of the gaskets.
- Gate valves with flanged ends shall be installed in slightly open to fully open position.
- Gate valves with welding ends should be welded onto the pipeline in the slightly closed position by an expert and with appropriate WPS. After welding, if necessary, local normalization should be performed and the inside of the pipeline should be cleaned to remove possible welding remains.

- At the moment of installation the influence of the load of the pipeline on the gate valve should be reduced. The same also applies for temperature oscillation, hydraulic impact and similar. The gate valve should not be used as a support for a pipeline.
- Each product after assembling is hydraulically tested leading to wetting the sealing of the package. As a result, before installation, may be difficult manipulation with hand wheel. This phenomenon does not affect the functionality of the product.
- It is possible after the installation, start-up and operating parameters are set to detect a leakage on the stem packing. In this case it is necessary to tighten the gland nuts equally. The tightness should not exceed more than necessary to allow comfortable manipulation of the valve (opening / closing). If it is necessary, new stem packing rings of the same quality should be added to the packing.

WARNING!!!

- Do not disassemble or modify a valve in any way prior to installation. This will void the factory warranty.
- Each product after assembling is hydraulically tested the result of which is “wetting” of the sealing package. As a result, may be difficult manipulation with handwheel before installation. This do not effect on the functionality of product and this phenomenon will be eliminated after installation gate valve on the pipeline;
- You must not lift the valves using the connection flange holes or the hand wheel at the moment of the installation the valve on the pipeline – you should use lifting straps to secure the valves to the lifting equipment;
- Before installation the impurities should be removed from the pipeline or from the appliance;
- Remove protecting covers from the valve ends, degrease and clean the inside of the gate valve, and in case of a flanged connection, carefully clean the sealing surfaces;
- Confirm that the marks on the gate valve correspond to the projected parameters of the plant (e.g. size, pressure, material etc.) and installation is according to allowable flow direction;
- Confirm that the velocity of the fluid at the place of the installation is in range of the recommended velocity;
- During the installation check if there is enough space for normal and safe manipulation;
- At the moment of testing of a pipeline or an installed appliance valve; take care about the predicted maximal differential pressure.
- **The valve should not be used as a support for a pipeline.**

5. Usage and maintenance

- It is convention during usage of the gate valves that all minor defects, if operating conditions allow, should be repaired on the spot. If not, the gate valve should be dismantled from the site in order to perform a full repair. If the gate valve is severely damaged it should be replaced with a new one. Such repairs protect gate valves against further deterioration, being permanently out of work and being the cause of severe accidents in the plant.
- The valve stem packing should be the subject of particular attention as it is important for the qualitative maintenance of tightness and should be periodically checked. If leakage at the stem packing is detected, the gland nuts should be tightened slowly (Fig. 2). When gland nuts are tightened, if the gland falls down more than twice the packing ring height, new packing rings should be added to the stem packing.

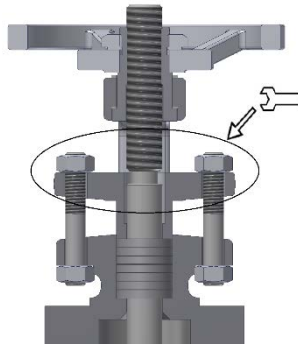

Fig. 2 Stem packing gland tightening

- After a longer period of use, the valve stem packing becomes rigid and unusable so a replacement should be done. When the replacement of stem packing is performed, remains of the old packing should be removed carefully and the sealing chamber should be thoroughly cleaned before the new packing is installed. The packing rings of the new stem packing should be identical in quality as before, especially for valves with high working parameters. Individual packing rings should be used for stem packing (Fig. 3) and arranged in a manner that the connection of one ring is at angle of 90° to the connection of next one.



Fig. 3 Stem packing ring

- In case of leakage through gaskets between gate valve connection flanges or between the bonnet and body, it is necessary to make replacements of the gaskets as soon as possible to prevent damage of the sealing surfaces due to erosion.
- The gate valves equipped with grease nipple should be lubricated every month, or twice a year, if they are rarely used. It is recommended to replace the grease in bushes during every general overhaul or during the pipeline revision. The type of grease depends on the temperature in the plant. Remote controls, bushings and gearboxes should be lubricated depending on how frequently they are used, every six or twelve months.

WARNING!!!

- During usage gate valves must be completely in an open or closed position;
- If, when a gate valve is overhauled, a decrease of wall thickness of more than 30% is detected at any of the ports (due to erosion) the valve should stop being used;
- Any time when a gate valve is dismantled or reinstalled the gaskets should be replaced with new ones with the appropriate quality;
- Valve opening and closing by handwheel, should be done without use of auxiliary means such as a rod or similar;
- Gate valve maintenance and manipulation during use should be done only by experts and persons well trained for such purpose;
- At the moment of installation of the plant sudden and extreme change of pressure and temperature should be avoided;
- A Strainer being installed before the valve will increase its reliability and proper working.

6. Service and repair

- Only authorized persons should perform service and repair with appropriate tools and, if it is possible, using original spare parts. Personal protection should be applied in accordance with valid regulations and legalizations.
- Attention should always be paid to the reliability of the valves and parameters of the working implementation / plant, and only materials which can successfully replace those originally installed should be used.
- For highly reliable gate valves (valves which work with high temperatures, high pressures or with dangerous fluids) any service, repair or replacement should be done professionally and responsibly in accordance with valid regulations for safe working conditions at the plant.
- Before the service or reinstallation of the valves, the plant or installation should be taken out of operation (pressure 0 bar, temperature of valves should be the same temperature as the environment).
- Every Gate valve serviced or repaired should be subject to all necessary tests usually performed for a newly produced Gate valve.
- Bolts for connection between body and bonnet should be tightened evenly and crosswise applying appropriate torque when the Gate valve is in the open position.
- For high temperature and high pressure applications after 24 hours of operation, all nuts shall be re-tighten diametrically opposite up to design stress. This action compensate any relaxation or creep. Periodic inspection is recommended, thereafter.
- Bearing in mind the responsibility of the equipment in the eventual replacement of materials / parts, installed materials must be at least the same or better quality than to the originally.
- Possible torques for tightening are listed in Table 2 and the selection of torque depends on the material grade of bolts and nuts used, as well as the quality of the gasket of the bonnet.

Table 2.

Nominal bolt diameter	Material of bolts: B7	Material of bolts: B16	Material of bolts: B8
	Torque [Nm]	Torque [Nm]	Torque [Nm]
M10	55	55	20
M12	90	90	30
M14	140	140	45
M16	215	215	65
M18	270	275	85
M20	410	415	125

WARNING!!!

- Gaskets between the body and bonnet of the valves should be manipulated with high precautions because they could contain stainless steel wire which can cause severe injuries.

7. Possible malfunctions and solutions

During the period of usage of the installed gate valve malfunctions may occur. Only experts in the premises of the user should undertake repairs. The most common cause of malfunctions and how to overcome such situations is listed in Table 3.

Table 3.

Failure	Possible cause	Troubleshooting
Absence of flow	Gate valve is in closed position	Open the gate valve
	Protection covers are not removed	Remove protection covers from connection ends
	Gate valve is not completely open	Open the valve completely with handwheel (Pos.12)
	Dirty Gate valve or pipeline	Check and clean gate valve or pipeline
Difficult manipulation	Dry stem (Pos. 4)/stem nut (Pos.5)	Grease stem (Pos.4)
	Gland nuts (Pos.11) are too tight	Slightly loosen Gland nuts (pos.11) with precaution to preserve sealing of the stem packing (Pos.9)
Leakage on bonnet gasket	Nuts (Pos.7) are not tightened	Tighten Nuts (Pos.7)
	Bonnet gasket (Pos.8) is damaged	Disassemble bonnet (Pos.2) and replace bonnet gasket (Pos.8) with new one
Leakage on stem packing	Gland nuts (Pos.11) are not tightened	Tighten Gland Nuts (Pos.11)
	Stem packing (Pos.9) lost own functionality	Completely open the valve and carefully add new stem packing rings to original stem packing (Pos.9) or replace whole stem packing (Pos.9) with new one
Leaking on seat	Gate valve isn't completely closed	Turn handwheel (Pos.12) in direction indicated for closing without auxiliary means
	Mechanical damages of seat or wedge	Contact the manufacturer
	Working medium contains solid dirt particles	Clean Valve thoroughly. We recommend installation of Strainer before Gate Valve

8. Guarantee

- The Guarantee issued by “TERMOVENT” SC confirms the safe working of its products under conditions when these products are properly installed in accordance with the instructions in the documentation given to the customer, and usage is in accordance with approved technical conditions and working parameters.
- The Guarantee is void if inappropriate parts from other manufacturers are implemented, if the user changes construction, or if there is any decline in function or malfunction due to natural wear and tear.

Guarantee conditions:

- The Guarantee is valid for defective parts or defective products, when any such defect is confirmed by an expert engaged by the customer and approved by experts from our company. In such a situation “TERMOVENT” SC will replace the defective part(s) or defective product(s).
- Replacement of defective part(s) or defective product(s) with new one(s) should be done only by an expert engaged by the customer upon approval or by instruction of our experts and in accordance with the instructions for installation.
- The Guarantee period is not valid if installation and manipulation of the valves isn't in accordance with these instructions. The Guarantee period for all replaced parts or product(s) starts from the moment the replacement(s) is/are done.

The Guarantee is valid only if the valves are handled, stored, installed, used and maintained in full accordance to the Instructions and recommendation listed in this Document.

WARNING!!!

- After detection of mistakes "Termovent" SC should be informed immediately.
- Claims must be made in writing.