

INSTRUCTIONS

FOR INSTALLATION, OPERATION AND MAINTENANCE OF

High Pressure Lift Check Valves [CHPL]



Table of Contents

1.	General safety information's	3
2.	Product description	3
3.	Transport and storage	5
4.	Installation and start-up	6
5.	Usage and maintenance	7
6.	Service and repair	8
7.	Possible malfunctions and solutions	9
8.	Guarantee	9



1. General safety information's

Instructions for installation, start-up and maintenance during the period of exploitation of valves manufactured in the “Termovent SC” should be used as a manual intended for all personnel directly or indirectly involved in dealing with the aforementioned goods.

These instructions are only related to High Pressure Lift Check Valves.

Operators in charge of installation, operation and maintenance of lift check valves during the period of use, should be fully trained for the correct / optimal performance of these tasks.

Because lift check valves in working conditions have hot parts (body and cover) and may cause burns, the operator has an obligation to undertake all necessary precautions to avoid such by using protective facilities.

Before the service or reinstallation of the valves, the plant or installation should be taken out of operation (pressure 0 bar, temperature of valves should be the same temperature as the environment).

These products are recyclable. No ecological hazard is anticipated with the disposal of these products providing due care is taken.

2. Product description

The main purpose of the Lift check Valves is to stop fluid flow through pipeline in one direction.

If anything is unclear at the time of installation, start-up or during use, and not covered in these instructions, the departments of the “TERMOVENT” SC should be contacted directly in order to obtain the required support.

All Lift check Valves manufactured in “TERMOVENT” SC are marked with following marks:

- Identification of manufacturer (“Termovent SC” logo);
- Nominal diameter of valve DN (mm) or NPS (inch);
- Nominal pressure PN or Class rating (#);
- Material designation of body and cover;
- Body and cover melt identification/heat number;
- Trim identification- material grade for disc and seat;



- Unique serial number;
- Arrow mark for allowable direction of flow;
- Date of manufacture (month and year) ;
- Maximum allowable pressure at maximal temperature (EN 12561 or ANSI B16.34)
- The product standard designation: i.e. ASME B16.34;
- Valve ends flanges and body/bonnet flanges grooved for ring joints and the rings to be used with them shall be marked with corresponding ring number;
- CE marking (if it is manufactured in accordance with 2014/68/EU (PED 97/23/EC));
- Other marks in accordance with customer request or product standard.

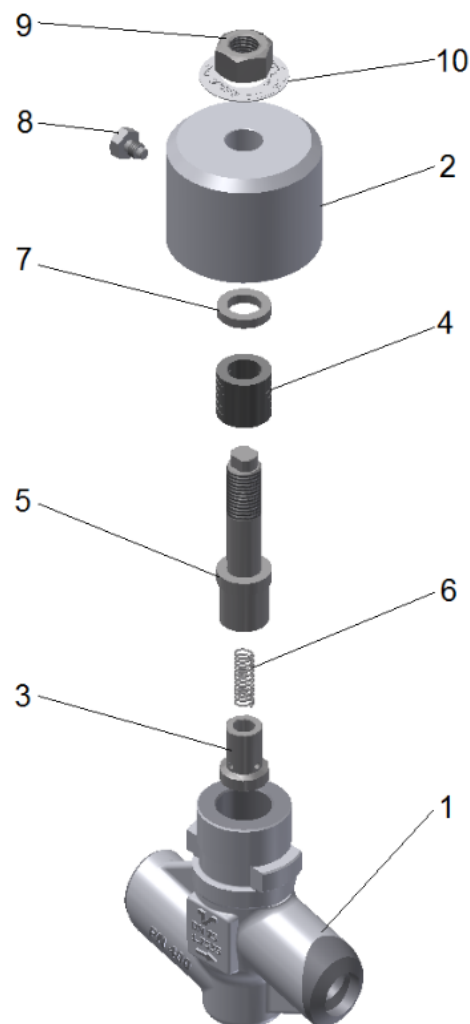

Fig. 1 Parts



Table 1

Pos.	Part Name	Quantity	Spare Parts
1	Body	1	
2	Cover	1	
3	Disc	1	
4	Body Packing	1 set	YES
5	Guide Sleeve	1	
6	Spring	1	
7	Spacer Ring	1	
8	Security Bolt	1	
9	Tightening Nut	1	
10	Nameplate	1	

3. Transport and storage

Transport and storage of lift check valves should be performed at a temperature between -20°C to $+60^{\circ}\text{C}$ and should be protected against outer and atmospheric influences, as well as protecting painted surfaces against damage. The purpose of painted surfaces is to protect valves against corrosion during transport and storage.

The basic version of lift check valves are protected with particular/special paints applied to the outer parts and protective preservatives inside. As such, any corrosion is prevented for a period of 6 months. Protection for special conditions is applied only with prior agreement.

It is recommended to store the lift check valves in closed, dry and ventilated storage facilities and to protect valves against any atmospheric influence. In order to avoid the appearance of corrosion before the expiry of protection it is necessary to store the valves on a pallet/crate or other appropriate place.

WARNING !!!

- You must not lift the lift check valves using the connection flange holes
- You must not remove the protection covers from the valve connection ends



4. Installation and start-up

After the removal of the protection covers it is necessary to thoroughly clean inside the lift check valve with compressed air.

When installing valves with flanged ends it is necessary to take into consideration the selection of adequate bolt material and the appropriate type of gasket depending on the type of working fluid, pressure, temperature, and the type of flange facing. It is necessary to install gaskets strictly in accordance with instructions given from the manufacturer of the gaskets.

Valves with welding ends should be welded onto the pipeline by an expert and with appropriate WPS. After welding, if necessary, local normalization should be performed and the inside of the pipeline should be cleaned to remove possible welding remains.

At the moment of installation the influence of the load of the pipeline on the valve should be reduced. The same also applies for temperature oscillation, hydraulic impact and similar. The valve should not be used as a support for a pipeline.

It is important to take care about the flow direction at the time of installation. The flow direction is indicated with the arrow mark casted or imprinted on the body of the lift check valve.

Mounting position must be in accordance with the instructions in this guide (Fig. 2)

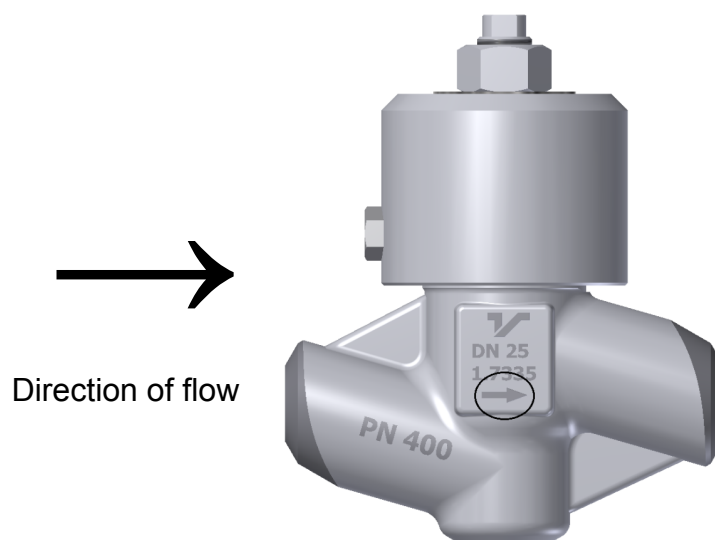

Fig. 2 Mounting position



WARNING !!!

- You must not lift the check valve using the connection flange holes at the moment of the installation on the pipeline – you should use lifting straps.
- Before installation the impurities should be removed from the pipeline or from the appliance;
- Remove protecting covers from the valve ends, degrease and clean the inside of the valve, and in case of a flanged connection, carefully clean the sealing surfaces;
- Confirm that the marks on the lift check valve correspond to the projected parameters of the plant (e.g. size, pressure, material etc.) and installation is according to allowable flow direction;
- Confirm that the velocity of the fluid at the place of the installation is in range of the recommended velocity;
- At the moment of testing of a pipeline or an installed appliance valve; take care about the predicted maximal differential pressure.
- **The valve should not be used as a support for a pipeline.**

5. Usage and maintenance

It is convention during usage of the valves that all minor defects, if operating conditions allow, should be repaired on the spot. If not, the valve should be dismantled from the site in order to perform a full repair. If the valve is severely damaged it should be replaced with a new one. Such repairs protect valves against further deterioration, being permanently out of work and being the cause of severe accidents in the plant.

In case of leakage through gaskets between valve connection flanges or between the bonnet and cover, it is necessary to make replacements of the gaskets as soon as possible to prevent damage of the sealing surfaces due to erosion.



WARNING !!!

- If, when a valve is overhauled, a decrease of wall thickness of more than 30% is detected at any of the ports (due to erosion) the valve should stop being used;
- Any time when a valve is dismantled or reinstalled the gaskets should be replaced with new ones with the appropriate quality;
- Valve maintenance and manipulation during use should be done only by experts and persons well trained for such purpose;
- At the moment of installation of the plant sudden and extreme change of pressure and temperature should be avoided;
- A Strainer being installed before the lift check valve will increase its reliability and proper working

6. Service and repair

Only authorized persons should perform service and repair with appropriate tools and, if it is possible, using original spare parts. Personal protection should be applied in accordance with valid regulations and legalizations.

Attention should always be paid to the reliability of the valves and parameters of the working implementation / plant, and only materials which can successfully replace those originally installed should be used.

For highly reliable valves (valves which work with high temperatures, high pressures or with dangerous fluids) any service, repair or replacement should be done professionally and responsibly in accordance with valid regulations for safe working conditions at the plant.

Before the service or reinstallation of the valves, the plant or installation should be taken out of operation (pressure 0 bar, temperature of valves should be the same temperature as the environment).

Every Lift check Valve serviced or repaired should be subject to all necessary tests usually performed for a newly produced Lift check Valve.

Bearing in mind the responsibility of the equipment in the eventual replacement of materials / parts, installed materials must be at least the same or better quality than to the originally.



WARNING !!!

- Manipulation with body packing should be with high precautions because they could contain stainless steel wire which can cause severe injuries.

7. Possible malfunctions and solutions

During the period of usage of the installed valve malfunctions may occur. Only experts in the premises of the user should undertake repairs. The most common cause of malfunctions and how to overcome such situations is listed in Table 2.

Table 2

Failure	Possible cause	Troubleshooting
Absence of flow	Protection covers are not removed	Remove protection covers from connection ends
	Improperly installed product in relation to the allowed flow	Install valve in allowed flow direction
Leakage on gasket	Nut (Pos.9) is not tightened	Tighten Nut (Pos.9)
	Body Packing (Pos.4) is damaged	Disassemble cover (Pos.2) and replace gasket (Pos.4) with new one
Leaking on the seat	Mechanical damages of seat or disc (Pos.3)	Contact the manufacturer
	Working medium contains solid particles	Clean Valve thoroughly. We recommend installation of Strainer before Check Valve

8. Guarantee

The Guarantee issued by “Termovent SC” confirms the safe working of its products under conditions when these products are properly installed in accordance with the instructions in the documentation given to the customer, and usage is in accordance with approved technical conditions and working parameters.

The Guarantee is void if inappropriate parts from other manufacturers are implemented, if the user changes construction, or if there is any decline in function or malfunction due to natural wear and tear.



Guarantee conditions:

The Guarantee is valid for defective parts or defective products, when any such defect is confirmed by an expert engaged by the customer and approved by experts from our company. In such a situation "Termovent SC" will replace the defective part(s) or defective product(s).

Replacement of defective part(s) or defective product(s) with new one(s) should be done only by an expert engaged by the customer upon approval or by instruction of our experts and in accordance with the instructions for installation.

The Guarantee period is not valid if installation and manipulation of the valves isn't in accordance with these instructions. The Guarantee period for all replaced parts or product(s) starts from the moment the replacement(s) is/are done.

Guarantee is valid only for following storage and maintenance conditions:

Crate and pallets with valves should be stored indoors in a building with access limited to authorized personnel only. In the case of an inappropriate storage place crates (or pallets) should be stored under an awning and should be protected against rain and moisture with an appropriate waterproof cover, again with access limited to authorized personnel only.

Valves should only be taken out of a crate or removed from the covering of a pallet just before installation and only quantity to be installed should be taken out / removed. After the valves for installation are taken out of a crate (or pallet) the crate/pallet should be closed/covered again.

Do not remove the protector covers from valves until installation.

Valves prepared for installation should be manipulated and transported in a careful manner to prevent possible mechanical damage.

WARNING !!!

- After detection of mistakes "Termovent SC" should be informed immediately.
- Claims must be made in writing.

