

# INSTRUCTIONS

FOR INSTALLATION,  
OPERATION  
AND MAINTENANCE OF

---

Globe Stop Valves according  
to BS 1873 and API 623 [VBS]

---

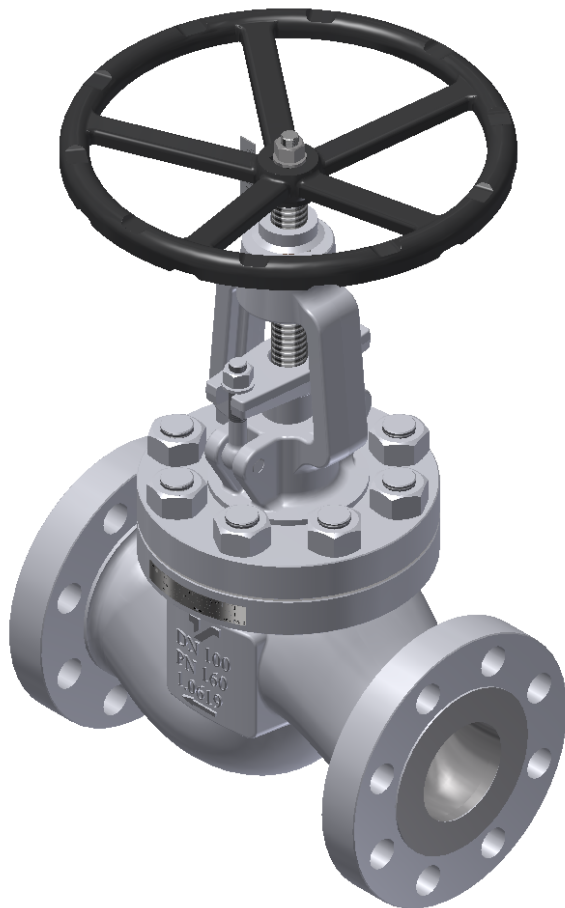

## Table of Contents

<b>1. General safety information's</b>	<b>3</b>
<b>2. Product description</b>	<b>3</b>
<b>3. Transport and storage</b>	<b>6</b>
<b>4. Installation and start-up</b>	<b>7</b>
<b>5. Usage and maintenance</b>	<b>9</b>
<b>6. Service and repair</b>	<b>11</b>
<b>7. Possible malfunctions and solutions</b>	<b>12</b>
<b>8. Guarantee</b>	<b>13</b>



## 1. General safety information's

Instructions for installation, start-up and maintenance during the period of exploitation of valves manufactured in the “Termovent SC” should be used as a manual intended for all personnel directly or indirectly involved in dealing with the aforementioned goods.

These instructions are only related to Globe Stop Valves according to BS 1873 and API 623.

Operators in charge of installation, operation and maintenance of valves during the period of use, should be fully trained for the correct / optimal performance of these tasks. If valves are equipped with mechanical actuators, the operator should be trained for the adequate operation of such valves.

Because valves in working conditions have hot parts (handwheel, body and bonnet) and may cause burns, the operator has an obligation to undertake all necessary precautions to avoid such by using protective facilities.

Before the service or reinstallation of the valves, the plant or installation should be taken out of operation (pressure 0 bar, temperature of valves should be the same temperature as the environment).

These products are recyclable. No ecological hazard is anticipated with the disposal of these products providing due care is taken.

## 2. Product description

The main purpose of the valves is to isolate fluid flow through pipeline (shut-off Valves).

If anything is unclear at the time of installation, start-up or during use, and not covered in these instructions, the departments of the “Termovent SC” should be contacted directly in order to obtain the required support.

All valves manufactured in “Termovent SC” are marked with following marks:

- Identification of manufacturer (“Termovent SC” logo);
- Nominal diameter of valve NPS (inch) or DN (mm);
- Nominal pressure Class rating (#);
- Material designation of body and bonnet;
- Body and bonnet melt identification/heat number;



- Trim identification- material grade for stem, disc and seat;
- Unique serial number;
- Arrow mark for allowable direction of flow;
- Maximum allowable pressure at maximal temperature
- Date of manufacture (month and year) ;
- The product standard designation: BS 1873 or API 623;
- Valve ends flanges and body/bonnet flanges grooved with ring joints corresponding ring number;
- CE marking (if it is manufactured in accordance with 2014/68/EU(PED 97/23/EC));
- API marking (if it is manufactured in accordance with API Specification)
- Other marks in accordance with customer request or product standard.



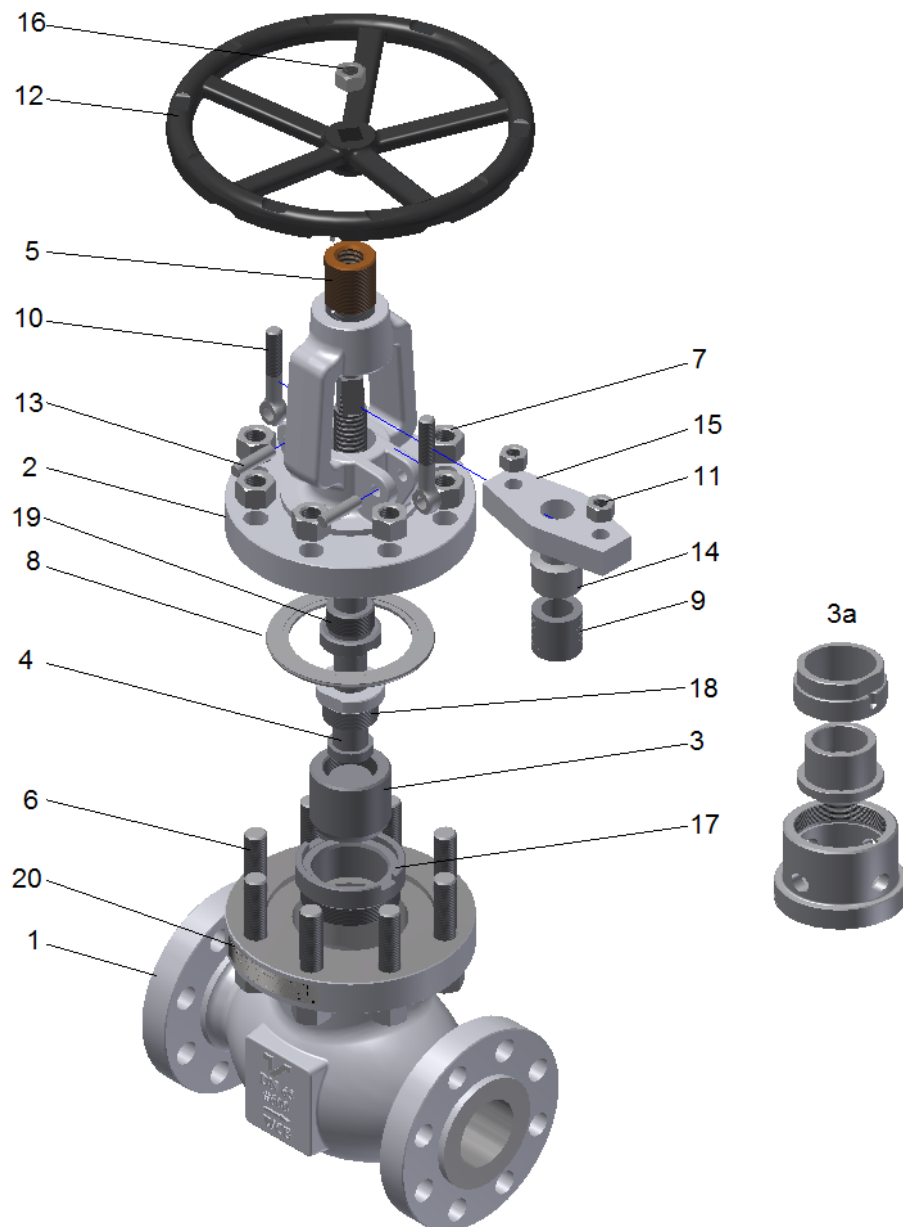

**Fig. 1 Parts names**

**Class 150:** Disc < NPS 8 ≥ Relief disc

**Class 300:** Disc < NPS 6 ≥ Relief disc

**Class 600:** Disc < NPS 3 ≥ Relief disc

**Class 900:** Disc < NPS 3 ≥ Relief disc

**Class 1500:** Disc < NPS 3 ≥ Relief disc

Table 1

Pos.	Part Name	Quantity	Spare Parts
1	Body	1	
2	Bonnet	1	
3	Disc*	1	
4	Stem	1	
5	Stem Nut	1	
6	Stud Bolts	**	
7	Nuts	**	
8	Bonnet Gasket	1	Yes
9	Stem Packing	1	Yes
10	Gland Bolts	2	
11	Gland Nuts	2	
12	Handwheel	1	
13	Gland Pin	2	
14	Packing Gland	1	
15	Gland Flange	1	
16	Handwheel Nut	1	
17	Body Seat	1	
18	Disc Nut	1	
19	Backseat bushing	1	
20	Nameplate	1	

\* 3-relief disc, 3a-disc

\*\* Quantity depend from DN and PN or Class

### 3. Transport and storage

Transport and storage of valves should be performed at a temperature between -20°C to +60°C and should be protected against outer and atmospheric influences, as well as protecting painted surfaces against damage. The purpose of painted surfaces is to protect valves against corrosion during transport and storage.

The basic version of valves are protected with particular/special paints applied to the outer parts and protective preservatives inside. As such,



any corrosion is prevented for a period of 6 months. Protection for special conditions is applied only with prior agreement.

It is recommended to store the valves in closed, dry and ventilated storage facilities and to protect valves against any atmospheric influence. In order to avoid the appearance of corrosion before the expiry of protection it is necessary to store the valves on a pallet/crate or other appropriate place.

### **WARNING !!!**

- You must not lift the valves using the connection flange holes or the handwheel – you should use lifting straps to secure the valves to the lifting equipment;
- You must not remove the protection covers from the valve connection ends;
- It is not advisable to store the valves in the ‘open’ position - store them in the ‘closed’ position.

## **4. Installation and start-up**

Valves are delivered with their disc in the closed position and they are ready for use. After the removal of the protection covers it is necessary to thoroughly clean inside the valve with compressed air without first opening the valve.

Closure of a valve is performed by turning the handwheel in a clockwise direction. On the handwheel is an arrow and the letter “C” indicating the closing direction, and another arrow and the letter “O” indicating the opening direction.

When installing valves with flanged ends it is necessary to take into consideration the selection of adequate bolt material and the appropriate type of gasket depending on the type of working fluid, pressure, temperature, and the type of flange facing. It is necessary to install gaskets strictly in accordance with instructions given from the manufacturer of the gaskets.

Valves with welding ends should be welded onto the pipeline by an expert and with appropriate WPS. After welding, if necessary, local normalization should be performed and the inside of the pipeline should be cleaned to remove possible welding remains.

At the moment of installation the influence of the load of the pipeline on the valve should be reduced. The same also applies for temperature oscillation, hydraulic impact and similar. The valve should not be used as a support for a pipeline.



It is important to take care about the flow direction at the time of installation. The flow direction is indicated with the arrow mark casted or imprinted on the body of the valve.

After assembling every single product is hydraulically tested which may cause swelling of the stem packing. This appearance could affect harder manipulation with hand wheel before products installation. Subsequently installation of the product on pipeline and after operating conditions are achieved, hand wheel manipulation became regular. This kind of appearing does not affect the functionality of the product.

It is possible after the installation, start-up and operating parameters are set to detect a leakage on the stem packing. In this case it is necessary to tighten the gland nuts equally. The tightness should not exceed more than necessary to allow comfortable manipulation of the valve (opening / closing). If it is necessary, new stem packing rings of the same quality should be added to the packing.

### **WARNING !!!**

- After assembling every single product is hydraulically tested which may cause swelling of the stem packing. This appearance could affect harder manipulation with hand wheel before products installation. Subsequently installation of the product on pipeline and after operating conditions are achieved, hand wheel manipulation became regular. This kind of appearing does not affect the functionality of the product;
- You must not lift the valves using the connection flange holes or the handwheel at the moment of the installation the valve on the pipeline – you should use lifting straps to secure the valves to the lifting equipment;
- Before installation the impurities should be removed from the pipeline or from the appliance;
- Remove protecting covers from the valve ends, degrease and clean the inside of the valve, and in case of a flanged connection, carefully clean the sealing surfaces;
- Confirm that the marks on the valve correspond to the projected parameters of the plant (e.g. size, pressure, material etc.) and installation is according to allowable flow direction;
- Confirm that the velocity of the fluid at the place of the installation is in range of the recommended velocity;
- During the installation check if there is enough space for normal and safe manipulation;
- At the moment of testing of a pipeline or an installed appliance valve; take care about the predicted maximal differential pressure.





## 5. Usage and maintenance

It is convention during usage of the valves that all minor defects, if operating conditions allow, should be repaired on the spot. If not, the valve should be dismantled from the site in order to perform a full repair. If the valve is severely damaged it should be replaced with a new one. Such repairs protect valves against further deterioration, being permanently out of work and being the cause of severe accidents in the plant.

The valve stem packing should be the subject of particular attention as it is important for the qualitative maintenance of tightness and should be periodically checked. If leakage at the stem packing is detected, the gland nuts should be tightened slowly (Fig. 2). When gland nuts are tightened, if the gland falls down more than twice the packing ring height, new packing rings should be added to the stem packing.

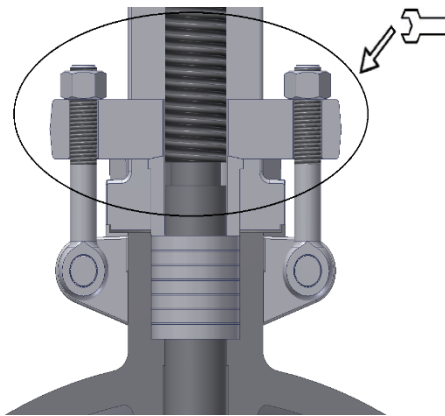

**Fig.2 Stem packing gland tightening**

After a longer period of use, the valve stem packing becomes rigid and unusable so a replacement should be done. When the replacement of stem packing is performed, remains of the old packing should be removed carefully and the sealing chamber should be thoroughly cleaned before the new packing is installed. The packing rings of the new stem packing should be identical in quality as before, especially for valves with high working parameters. Individual packing rings should be used for stem packing (Fig. 3) and arranged in a manner that the connection of one ring is at angle of 90° to the connection of next one.



**Fig.3 Stem packing ring**

In case of leakage through gaskets between valve connection flanges or between the bonnet and body, it is necessary to make replacements of the gaskets as soon as possible to prevent damage of the sealing surfaces due to erosion.

The valves equipped with grease nipple should be lubricated every month, or twice a year, if they are rarely used. It is recommended to replace the grease in bushes during every general overhaul or during the pipeline revision. The type of grease depends on the temperature in the plant. Remote controls, bushings and gearboxes should be lubricated depending on how frequently they are used, every six or twelve months.

Valves delivered with actuator is adjusted for proper work. Globe valves delivered with connection for later build on it the electric actuator must be adjusted. Closing of globe valves should be adjusted by torque switch and the opening by limit switch. The setting of torque and limit switches must be in accordance with the instructions of the manufacturer of the actuator.



**WARNING !!!**

- During usage stop valves must be completely in an open or closed position;
- If, when a valve is overhauled, a decrease of wall thickness of more than 30% is detected at any of the ports (due to erosion) the valve should stop being used;
- Any time when a valve is dismantled or reinstalled the gaskets should be replaced with new ones with the appropriate quality;
- Valve opening and closing by handwheel, should be done without use of auxiliary means such as a rod or similar;
- Valve maintenance and manipulation during use should be done only by experts and persons well trained for such purpose;
- At the moment of installation of the plant sudden and extreme change of pressure and temperature should be avoided;
- A Strainer being installed before the valve will increase its reliability and proper working.

## 6. Service and repair

Only authorized persons should perform service and repair with appropriate tools and, if it is possible, using original spare parts. Personal protection should be applied in accordance with valid regulations and legalizations.

Attention should always be paid to the reliability of the valves and parameters of the working implementation / plant, and only materials which can successfully replace those originally installed should be used.

For highly reliable valves (valves which work with high temperatures, high pressures or with dangerous fluids) any service, repair or replacement should be done professionally and responsibly in accordance with valid regulations for safe working conditions at the plant.

Before the service or reinstallation of the valves, the plant or installation should be taken out of operation (pressure 0 bar, temperature of valves should be the same temperature as the environment).

Every Globe Valve serviced or repaired should be subject to all necessary tests usually performed for a newly produced Globe Valve.



Bolts for connection between body and bonnet should be tightened evenly and crosswise applying appropriate torque when the Globe Valve is in the open position.

Possible torques for tightening are listed in Table 2 and the selection of torque depends on the material grade of bolts and nuts used, as well as the quality of the gasket of the bonnet.

**Table 2**

Nut	M8	M10	M12	M14	M16	M20	M24	M27	M30	M33	M36
Torque (Nm)	8÷20	15÷40	26÷65	42÷100	64÷150	125÷300	210÷500	305÷730	410÷1000	550÷1350	710÷1720

**WARNING !!!**

- Gaskets between the body and bonnet of the valves should be manipulated with high precautions because they could contain stainless steel wire which can cause severe injuries.

## 7. Possible malfunctions and solutions

During the period of usage of the installed valve malfunctions may occur. Only experts in the premises of the user should undertake repairs. The most common cause of malfunctions and how to overcome such situations is listed in Table 3.

**Table 3.**

Failure	Possible cause	Troubleshooting
Absence of flow	Valve is in closed position	Open the valve
	Protection covers are not removed	Remove protection covers from connection ends
	Globe valve is not completely open	Open the valve completely with handwheel (Pos.12)
	Dirty valve or pipeline	Check and clean valve or pipeline
	Dry stem (Pos. 4)/stem nut (Pos.5)	Grease stem (Pos.4)



Difficult manipulation	Gland nuts (Pos.11) are too tight	Slightly loosen Gland nuts (pos.11) with precaution to preserve sealing of the stem packing (Pos.9)
Leakage on bonnet gasket	Nuts (Pos.7) are not tightened	Tighten Nuts (Pos.7)
	Bonnet gasket (Pos.8) is damaged	Disassemble bonnet (Pos.2) and replace bonnet gasket (Pos.8) with new one
Leakage on stem packing	Gland nuts (Pos.11) are not tightened	Tighten Gland Nuts (Pos.11)
	Stem packing (Pos.9) lost own functionality	Completely open the valve and carefully add new stem packing rings to original stem packing (Pos.9) or replace whole stem packing (Pos.9) with new one
Leaking on seat	Valve isn't completely closed	Turn handwheel (Pos. 12) in direction indicated for closing without auxiliary means
	Mechanical damages of seat or disc	Contact the manufacturer
	Differential pressure to high	Check installed valve allowable flow direction. For valves without relief disc check maximum allowable differential pressure.
	Working medium contains solid dirt particles	Clean Valve thoroughly. We recommend installation of Strainer before Globe Valve

## 8. Guarantee

The Guarantee issued by "Termovent SC" confirms the safe working of its products under conditions when these products are properly installed in accordance with the instructions in the documentation given to the



customer, and usage is in accordance with approved technical conditions and working parameters.

The Guarantee is void if inappropriate parts from other manufacturers are implemented, if the user changes construction, or if there is any decline in function or malfunction due to natural wear and tear.

### **Guarantee conditions:**

The Guarantee is valid for defective parts or defective products, when any such defect is confirmed by an expert engaged by the customer and approved by experts from our company. In such a situation "Termovent SC" will replace the defective part(s) or defective product(s).

Replacement of defective part(s) or defective product(s) with new one(s) should be done only by an expert engaged by the customer upon approval or by instruction of our experts and in accordance with the instructions for installation.

The Guarantee period is not valid if installation and manipulation of the valves isn't in accordance with these instructions. The Guarantee period for all replaced parts or product(s) starts from the moment the replacement(s) is/are done.

### **Guarantee is valid only for following storage and maintenance conditions:**

Crate and pallets with valves should be stored indoors in a building with access limited to authorized personnel only. In the case of an inappropriate storage place crates (or pallets) should be stored under an awning and should be protected against rain and moisture with an appropriate waterproof cover, again with access limited to authorized personnel only.

Valves should only be taken out of a crate or removed from the covering of a pallet just before installation and only quantity to be installed should be taken out / removed. After the valves for installation are taken out of a crate (or pallet) the crate/pallet should be closed/covered again.

Do not remove the protector covers from valves until installation.

Valves prepared for installation should be manipulated and transported in a careful manner to prevent possible mechanical damage.

### **WARNING !!!**

- After detection of mistakes "Termovent SC" should be informed immediately.
- Claims must be made in writing.

